



## VML

**Safety solenoid valves for gas  
Slow opening and fast closing type  
DN10 ... DN80**

# VML

## Safety solenoid valves for gas Slow opening and fast closing type

### Contents

Description .....	2
Features .....	2
Functioning and application .....	3
Technical specifications .....	4
Gas flow chart (pressure drop) .....	6
Ordering information .....	8
Special versions and optionals .....	8
Design, installation and servicing .....	9
Standards and approvals .....	10

### Description

The VML type valve is a slow opening single-stage solenoid valve, normally closed (open when energized). This type of device is suitable for air or gas blocking and releasing controls, required in gas power burners, atmospheric gas boilers, industrial kilns and others gas consuming appliances.

### Features

The valves are made of aluminum alloy die-cast, with a wide range for inlet/outlet connections from DN10 up to DN80.

Pipe connections meet group 2 and backpressure sealing is compliant with class A, according to EN161 requirements.

Suitable for use with air and non-aggressive gases included in the 1, 2 and 3 families (EN 437). Special versions for aggressive gases (Biogas, COG).



The whole range can be provided in Ex-proof execution, for use in Zones 2 and 22, according to 94/9/EC Directive (ATEX).

The valve is open only when energized: if, for any reason, power supply goes down, the valve closes immediately (intrinsic safe).

Suitable for cycle operation and qualified for continuous service (100% ED).

Equipped with max. flow rate and start flow rate adjustment.

An incorporated fine mesh filter protects the valve seat and disc as well as downstream components and prevents dirty contamination.

Provided with G1/4 pressure gauge on two sides in the inlet chamber, to connect manometers, pressure switches, leakage tester or other gas equipments. Flanged models are provided with gauges also in the outlet chamber.

The coils are provided with terminal box or with ISO 4400 plug (optional). Both systems are provided with suitable cable gland to avoid water and dirty contamination.

All components are designed to withstand any mechanical, chemical and thermal condition occurring during typical service. Effective impregnation and surface treatments have been used to improve mechanical sturdiness, sealing and resistance to corrosion of the components.

Valves are 100% tested by computerized testing machineries and are fully warranted.

## Functioning and application

The VML type valve is a safety shutting device using auxiliary power supply.

When it is de-energized, the spring pushes on the seal disc, keeping the gas passage closed. Now, the inlet chamber is under the gas line pressure, and it forces on the disc too, improving the seal.

When the coil is powered the valve opens slowly because of the hydraulic brake, against the strength of the spring and gas pressure. The rapid stroke may be adjusted using the regulating screw on the top (see the installation and service instructions), to adjust the initial gas flow. Main flow and opening time can be adjusted also.

If the power supply is shut off, the valve rapidly closes, interrupting the gas flow.

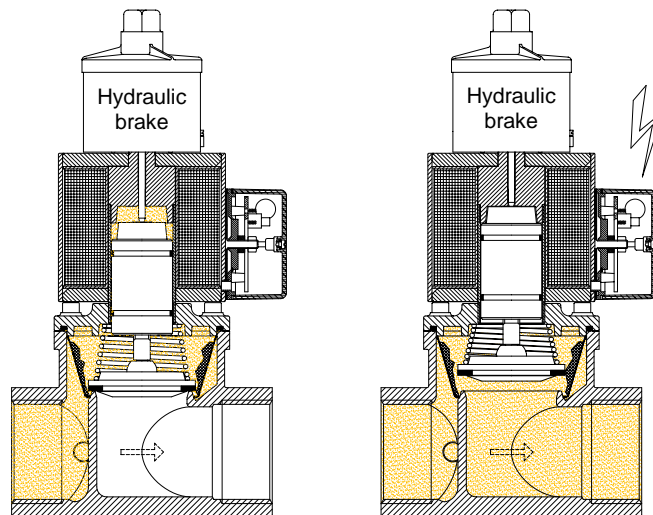

Fig.1

This kind of valve is normally installed as safety and regulating device in gas trains, for industrial applications and gas firing systems.

Figure 2 shows an example of installation.

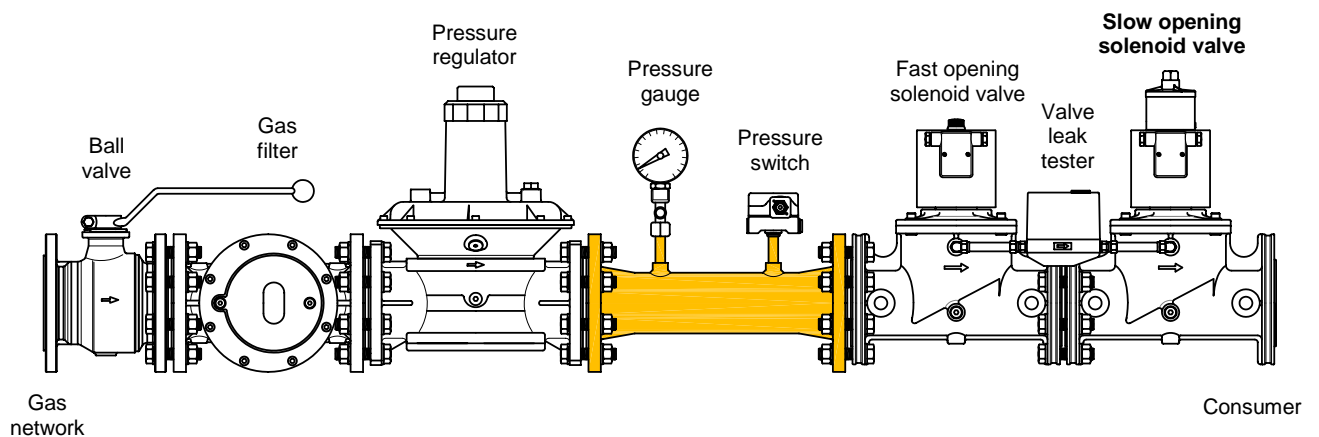

Fig.2

## Technical specifications

Tab. 1

<b>Connections</b>	Gas threaded f/f ISO 7-1 from Rp1/2 to Rp2½ Flanged PN16 – ISO 7005 from DN40 to DN80
<b>Voltage rating</b>	230 VAC 50/60 Hz 110 VAC 50/60 Hz 24 VAC/DC
<b>Voltage tolerance</b>	-15% ... +10%
<b>Power consumption</b>	see charts
<b>Ambient temperature</b>	-15°C ... +60°C
<b>Max. operating pressure</b>	200 mbar (20 kPa) 360 mbar (36 kPa) 500 mbar (50 kPa)
<b>Flow capacity</b>	see charts
<b>Closing time</b>	< 1 second
<b>Opening time</b>	Adjustable
<b>Filter (except brass models)</b>	600 µm
<b>Protection class</b>	IP54 (EN 60529) (optional IP65 with cable)
<b>Cable gland</b>	M20x1,5 (EN 50262) for terminal box PG 9 for standard plug
<b>Wires cross-section</b>	2,5 mm <sup>2</sup> max.
<b>Electrical safety</b>	Class I (EN 60335-1)
<b>Coil winding insulation</b>	Class H (200°C)
<b>Coil thermal resistance</b>	Class F (155°C)
<b>Materials in contact with gas</b>	Aluminium alloy Brass Stainless steel Plated steel Anaerobic adhesive Nitrile rubber (NBR) Fluoro elastomer (FPM) Polytetrafluoroethylene (PTFE)

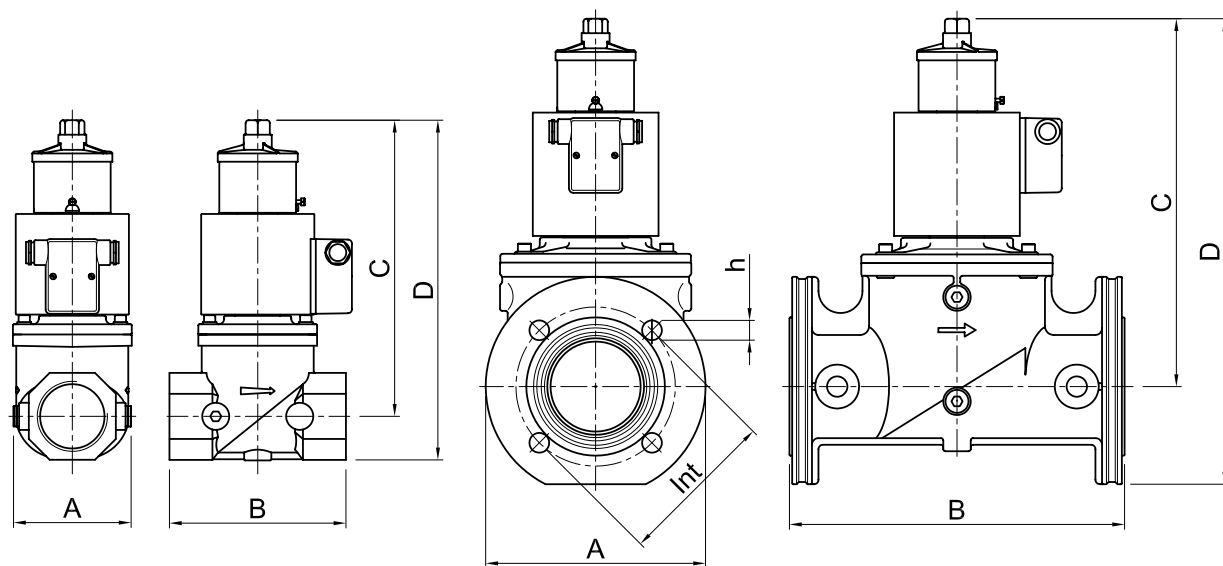

Fig. 3

Tab. 2

Material and connections	Power consumption 230VAC [VA/W]			Flow factor Kvs [m <sup>3</sup> /h]	Overall dimensions [mm]						Weight [Kg]	
	AISI	20 kPa	36 kPa		50 kPa	A	B	C	D	Int		h
Rp 3/8				20	2,9	88	77	180	196	-	-	1,8
Rp 1/2				20	4,8	88	77	180	196	-	-	1,8
Rp 3/4		35		35	9,5	88	96	200	222	-	-	2,7
Rp 1		35		35	12,0	88	96	200	222	-	-	2,7
Rp 1¼		45/180 <sup>2</sup>		45/180 <sup>2</sup>	20,0	120	153	261	294	-	-	6,2
Rp 1½		45/180 <sup>2</sup>		45/180 <sup>2</sup>	26,0	120	153	261	294	-	-	6,2
Rp 2		45/180 <sup>2</sup>		45/180 <sup>2</sup>	40,0	106	156	265	304	-	-	6,5
Rp 2½		45/180 <sup>2</sup>	60/240 <sup>2</sup>		63,0	180	218	324	370	-	-	12,1
DN 40 <sup>(1)</sup>		45/180 <sup>2</sup>		45/180 <sup>2</sup>	26,0	150	193	261	336	110	4x18	7,6
DN 50 <sup>(1)</sup>		45/180 <sup>2</sup>		45/180 <sup>2</sup>	40,0	165	196	265	348	125	4x18	8,3
DN 65		45/180 <sup>2</sup>	60/240 <sup>2</sup>		63,0	200	305	336	425	145	4x18	14,5
DN 80		45/180 <sup>2</sup>	60/240 <sup>2</sup>		80,0	200	305	336	425	160	8x18	14,5

(<sup>1</sup>) Flanged connection optional Kit    (<sup>2</sup>) Working/Starting

**Gas flow chart**

(Pressure drop)

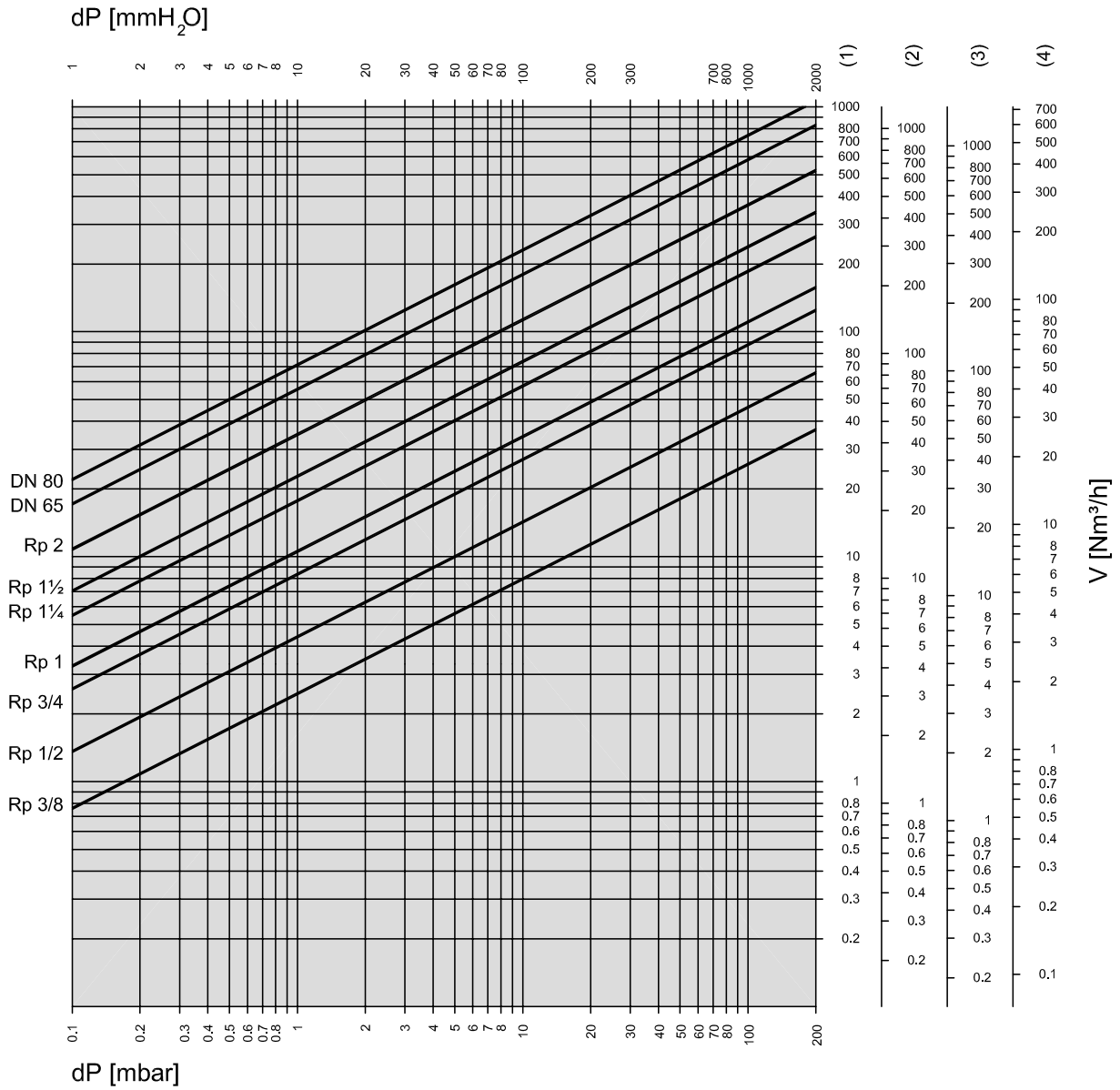

Fig. 4

**Formula of conversion from air to other gases**

$$V_{\text{GAS}} = k \cdot V_{\text{AIR}}$$

Tab. 3

Gas type	Specific gravity $\rho$ [Kg/m <sup>3</sup> ]	$k = \sqrt{\frac{1.25}{\rho_{\text{GAS}}}}$
(1) Air	1,25	1,00
(2) Natural gas	0,80	1,25
(3) Town gas	0,57	1,48
(4) LPG	2,08	0,77

15°C, 1013 mbar, dry

When the flow read on the diagram is referred to operating pressure instead of standard conditions, the pressure drop  $\Delta p$  read on the diagram must be multiplied for the factor: (1+ relative pressure in bar)

*Example:*

In the 2" solenoid valve with an air flow of 80 Nm<sup>3</sup>/h there is a pressure drop  $\Delta p = 5$  mbar. If we consider that 80 m<sup>3</sup>/h is the flow at 200 mbar of inlet pressure, then the pressure drop to be consider is:

$$\Delta p = 5 \times (1 + 0,2) = 6 \text{ mbar}$$

Normally, pressure drop and flow rate for the valves are read from the gas flow diagram. However, the valves can also be chosen in accordance with the characteristic "Kvs value" which is shown in table 2.

The selection of the valve requires the calculation of the Kv under the operating conditions.

Considering only subcritical pressure drops:

$$\Delta p < \frac{p_1}{2}$$

Kv can be calculated with the formula:

$$Kv = \frac{V}{514} \sqrt{\frac{\rho(t+273)}{\Delta p \cdot p_2}}$$

where

- V = flow rate [Nm<sup>3</sup>/h]
- Kv = flow factor [m<sup>3</sup>/h]
- $\rho$  = density [Kg/m<sup>3</sup>]
- p<sub>1</sub> = absolute inlet pressure [bar]
- p<sub>2</sub> = absolute outlet pressure [bar]
- $\Delta p$  = differential pressure p<sub>1</sub>-p<sub>2</sub> [bar]
- t = media temperature [°C]

To the Kv value calculated from operating conditions we add an allowance of 20%, to obtain the minimum Kvs value which the valve should have:

**Kvs > 1,2 Kv**



Valve must be selected considering the following:

- Pressure drops  $\Delta p \leq 0,1 p_1$  are recommended and  $\Delta p > p_1/2$  are always inadvisable
- Flow velocities  $w \leq 15$  m/s are recommended and  $w > 50$  m/s are always inadvisable.

## Ordering information

● Available

Tab.4

	Material and connections	Model	200 mbar				360 mbar				500 mbar			
			AISI	230V	110V	24V	12V	230V	110V	24V	12V	230V	110V	24V
Threaded	Rp 3/8	VML0			●						●	●		
	Rp 1/2	VML1			●						●	●		
	Rp 3/4	VML2	●	●	●						●	●		
	Rp 1	VML3	●	●	●						●	●		
	Rp 1¼	VML35	●	●	●						●	●		
	Rp 1½	VML4	●	●	●						●	●		
	Rp 2	VML6	●	●	●						●	●		
	Rp 2½	VML7T	●	●			●	●						
Flanged	DN 40	VML4F	● <sup>1</sup>	● <sup>1</sup>	● <sup>1</sup>						● <sup>1</sup>	● <sup>1</sup>		
	DN 50	VML6F	● <sup>1</sup>	● <sup>1</sup>	● <sup>1</sup>						● <sup>1</sup>	● <sup>1</sup>		
	DN 65	VML7	●	●			●	●						
	DN 80	VML8	●	●			●	●						

<sup>(1)</sup> Flanged connections optional kit

## Special versions and optionals

- Additional G1/4 gauges in the outlet chamber: on request for the sizes 1"¼, 1"½ and 2" (standard from DN65 to DN80).
- G1/8 connection on the bottom to fit a closed position indicator micro-switch (PCS type): on request from 3/4" to 2" (standard from DN65 to DN80). To install the micro-switch the adapting kit must be required.
- Protection class can be increased up to IP65. The valves will be provided with a sealed terminal box and cable set.
- The whole range can be provided with a special cable gland and Ex-proof marking for use in Zones 2 and 22, according to 94/9/EC Directive (ATEX):
 

category	II 3 G,D
protection mode	Ex n A II T4 X
	Ex tD A 22 IP54 T135 X
- The whole range can be provided with electrical connection made by standard plug ISO 4400 (optional with LED indicator).
- The threaded models Rp1½ and Rp2 can be provided with flanged connections using an optional kit (version F).
- The whole can be supplied in special versions for aggressive gases such as biogas (version J) and COG (version K), they are free of non-ferrous metals and provided with special seals.



Manufacturer reserves the right to update or make technical changes without prior notice.

## Design, installation and servicing

To assure a proper and safe operation, as well as a long service life of the valve, consider the following recommendations during the design of the system where the valve will be installed:



- ✓ Ensure that all the features of your system comply with the specifications of the valve (gas type, operating pressure, flow rate, ambient temperature, electrical voltage, etc.).
- ✓ Valve may be mounted with coil in horizontal or vertical position, not upside down. Coil may be oriented 360 degrees in any direction.
- ✓ In the event of vertical pipe, the flow direction should be from bottom to top.
- ✓ After removing the end caps make sure no foreign body will enter into the valve during handling or installation (e.g. swarf or excessive sealing agent).
- ✓ A gas filter should be always installed upstream the valve.
- ✓ Ensure that installing area is protected from rain and water splashes or drops.
- ✓ Perform leak and functional tests after mounting (max. testing pressure 1,5 Pmax).
- ✓ The continuous service (100% ED) causes inevitable coil heating, depending on working environment. Never install the valve close to walls or other equipments. To improve the coil cooling, install the valve allowing free air circulation.
- ✓ Perform maintenance according to service instructions at least once a year (most often for aggressive gases).
- ✓ Due to seals aging, to ensure safe operation, we recommend the valve replacement after 10 years from the date of manufacture stamped on the product.
- ✓ This control must be installed in compliance with the rules in force.
- ✓ Make sure all works are performed by qualified technicians only and in compliance with local and national codes.
- ✓ To prevent product damage and dangerous situations, read carefully the instructions supplied with the product before use.

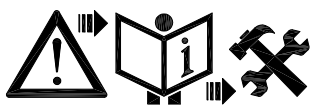

## Standards and approvals

The valves are designed and manufactured according to European Directive on the gas appliances 2009/142/EC and the certification has been issued by the notified Body



GASTEC CERTIFICATION B.V.  
Wilmersdorf, 50  
NL-7323 AC Apeldoorn  
**CE Reg.-No 0063AQ1350**



The following standards/technical specifications have been fulfilled:

- ATEX (94/9/EC) when shown upon the product
- Electromagnetic Compatibility (2004/108/EC)
- Low Voltage Directive (2006/95/EC)
- RoHS II (2011/65/UE)

The valves comply with the Technical Regulation 753 of Russian Federation concerning the security of machinery and equipment and the certification has been issued by the Body



«INTERCERT» Ltd  
Str. Profsoyuznaya, 93 A, of. 423  
RU-117279 Moscow

**Certificate No.: C-IT.AB86.B.04357**

The valves meet the requirements of functional safety of electrical systems according to the European standard IEC EN 61508 and are certified for systems up to SIL3 (Safety Integrity Level) by:

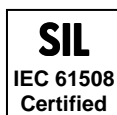

TÜV Italia Srl - Gruppo TÜV SÜD  
Via Carducci 125  
I-20099 Sesto San Giovanni (MI)

**Certificate No.: C-IS-212401-01**



Italia

Quality Management System is certified according to UNI EN ISO 9001 and the monitoring is carried out by the notified body:

Kiwa Gastec Italia Spa  
Via Treviso, 32/34  
I- 31020 San Vendemiano (TV)



Elektrogas is a brand name of:

Elettromeccanica Delta S.p.A.  
Via Trieste 132  
31030 Arcade (TV) - ITALY  
tel +39 0422 874068  
fax +39 0422 874048  
www.elektrogas.com  
www.delta-elektrogas.com  
info@delta-elektrogas.com

Copyright © 2012  
All rights reserved